

Connected door and seat functions: Brose creates new experience for vehicle access



Frankfurt am Main (13. September 2017) Comfortable, individual and connected – Brose will showcase the intelligent interaction between its door and seat functions in a near-

series concept car at the International Motor Show. The car recognizes the driver, the door opens automatically and the side bolsters on the front seats are lowered to make entering the vehicle easier. This makes vehicle access more comfortable and convenient than ever before – and a new experience for the driver, who is also greeted with projections on the ground.

A core element of these comfort features is a power side door drive that was systematically developed by Brose. The hinged car door is opened and closed using a smartphone or gestures and can even be operated on slopes and in angled positions. What is today a comfort feature will become essential in the age of autonomous driving or car-sharing – because if passengers do not close the door properly when exiting, the vehicle has to be able to do this itself before driving off. The drive uses existing door interfaces, so it can also be offered as an optional feature. Compact packaging means that the product can be flexibly adapted to different customer or vehicle requirements. Series production will start in 2020.

Brose has systematically expanded its expertise in the interaction of mechanical, electric and electronic systems to include sensor technology. It will showcase the system with additional functions including power locks and a radar sensor in the door, which identifies obstacles when the door is opened and stops it before a collision occurs. A capacitive sensor in the door provides anti-trap protection for increased safety.

Brose is picking up on the trend toward networked communication between the driver and the vehicle with light signals on the vehicle door and liftgate. As well as greater individualization, such functions offer advantages for car sharing, for example, by making it easier to identify the right vehicle.

More comfort also for decklids

Brose offers a new cable decklid drive for sedans and coupes to make it easier to open and close the trunk. The adjuster is located in the lid spring and is connected with the drive via Bowden cables. Because it is decoupled from the motor, the drive operates particularly quietly and can be flexibly integrated depending on the available space, for example in the side boxes. The mechatronics specialist used standard components from window regulators for this innovative solution, which creates significant cost advantages.

System approach for greater comfort and safety

Brose's IAA exhibit will show how door and seat functions work together as a system to offer drivers a completely new experience. The side bolsters are lowered automatically for comfortable vehicle access. The seatbelt and the belt lock move toward the user to make it easier to buckle up. Sensor technology actively adapts the new four-way headrest to the passenger's size and position. The design also gives manufacturers maximum creative freedom as the adjusters are completely integrated in the headrest and do not take up any space in the backrest.

The next level in comfort is a vibration massage in time with the music. Specially developed algorithms transform the signal from the sound system into a rhythmic massage to enhance the musical experience. This function is already a sought-after lifestyle feature for many

vehicle manufacturers. Brose is presenting another, extremely effective application at the IAA 2017: as a warning signal. Vibration can be used to immediately warn the driver of hazardous situations, for example if they fall asleep for a second, to support the lane assist function or as an alarm for automated driving.



Comfortable and safe vehicle access is shown at Brose's concept vehicle which unites functionalities of seats and doors with sensor technology.

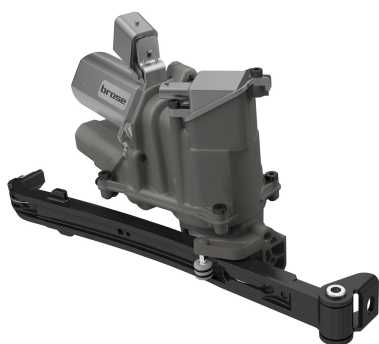

The compact side door drive by Brose can adapt to different customer and vehicle requirements. Series production starts in 2020.

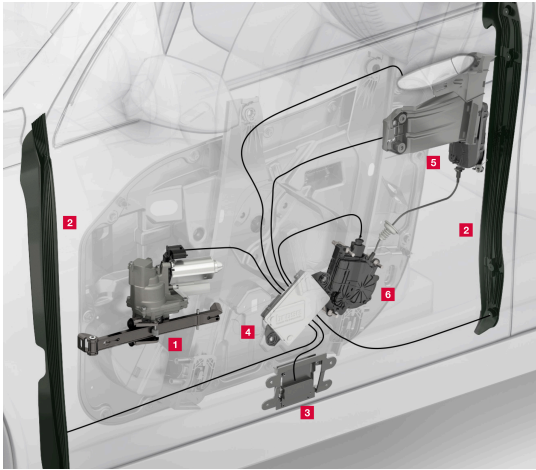

The Brose door drive system comprises the (1) drive, (2) anti-trap and (3) collision protection sensors, the (4) control unit and (5) open-by-wire latch with (6) power cinching unit.